



PONTO DE ENCONTRO – LISBOA E.NOVA

6th November



PONTO DE ENCONTRO – LISBOA E.NOVA

6th November



opening day, 1941, with "Marechal" Carmona and Cardeal Cerejeira





**CONCURSO PÚBLICO DE CONCEÇÃO DA SOLUÇÃO ARQUITETÓNICA
PARA A "ZONA DE ALVENARIA" DO BAIRRO DA BOAVISTA EM LISBOA**

PROGRAMA PRELIMINAR



Alvenaria Social Housing Project (2013-....)

Lisbon, Portugal

a project by

Alexandre Dias, Bruno Silvestre & Luis Spranger

Alvenaria Social Housing Project (2013-....)

Lisbon, Portugal

460 homes

138 1 bedroom , **184** 2 bedroom, **92** 3 bedroom, **46** 4 bedroom





IC 19

CRIL

Associação
Casapiana de
Solidariedade

Estrada do Outeiro

Clube Desportivo
Lisboa e Águas

Parque Florestal de Monsanto





the site, 1970's



the site, 2013

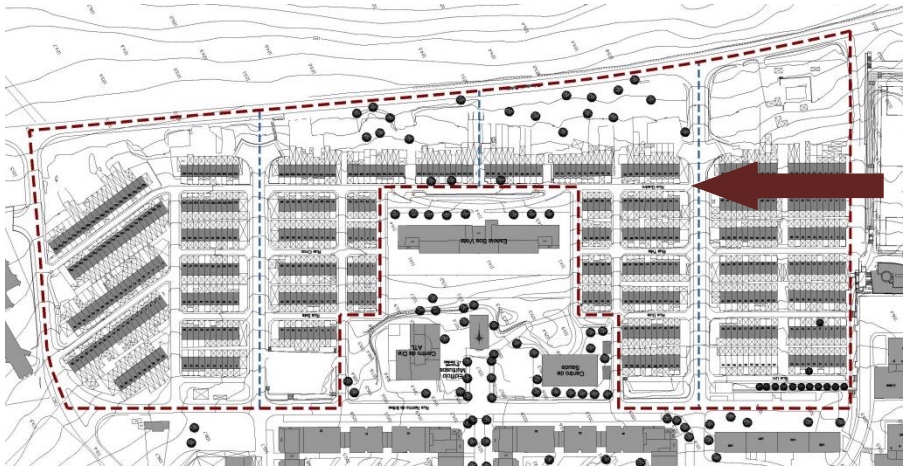

the site, 2013



the site, 2013



the site, 2013

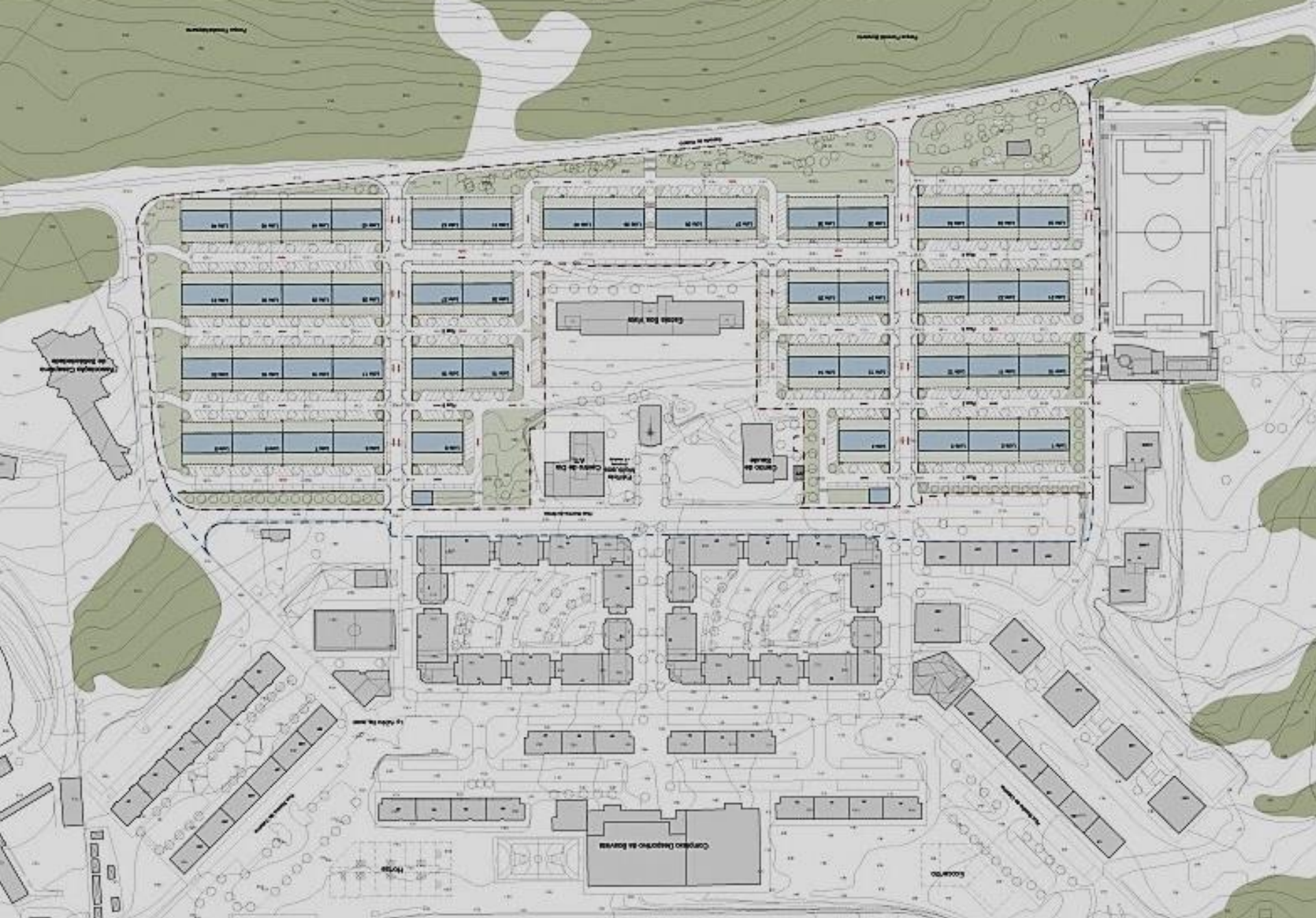

the masterplan

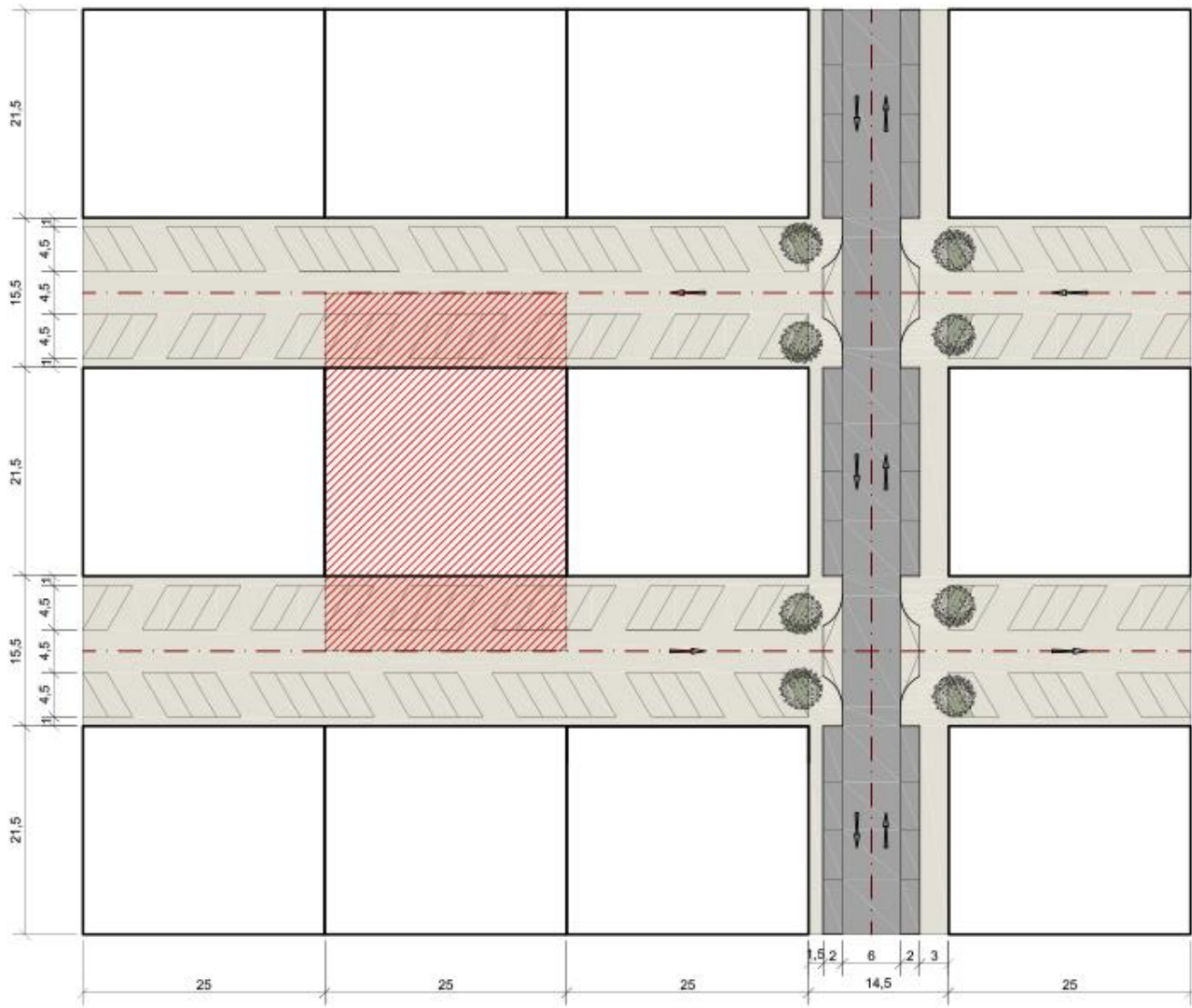

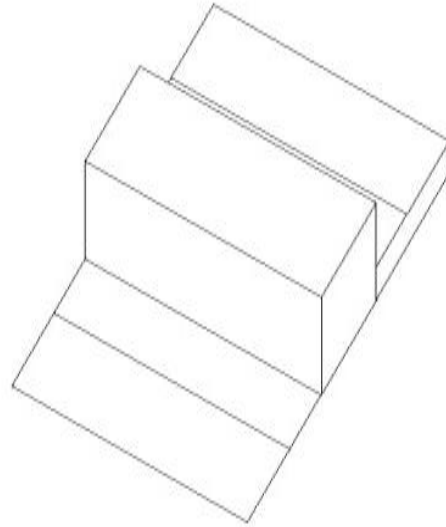

the solid bar...

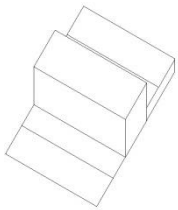
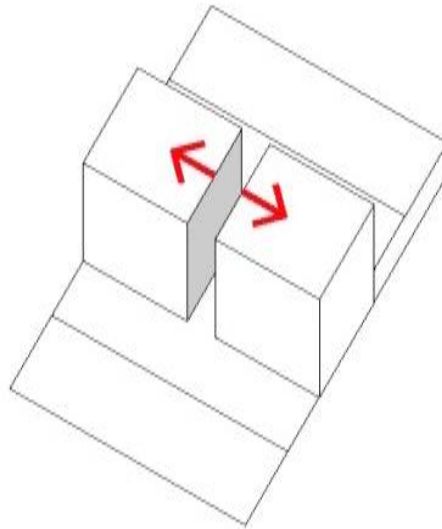

...is cut in two halves...

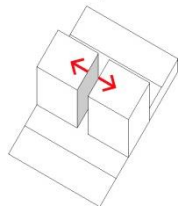
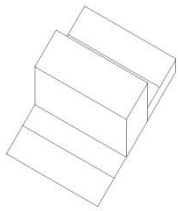
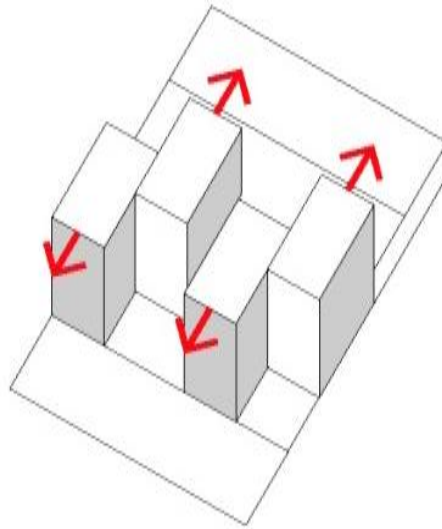

...each half is further divided in two halves and shifted position...

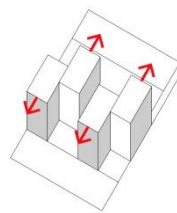
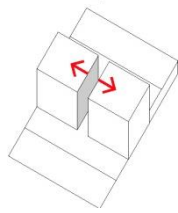
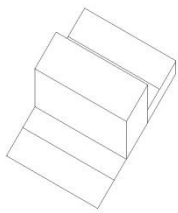
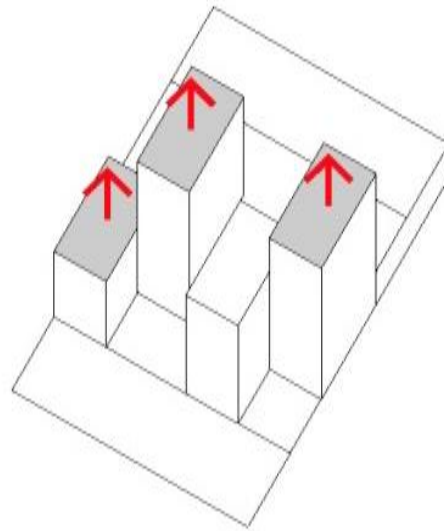

...roof levels adjusted to suit accommodation...

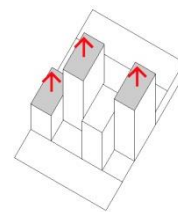
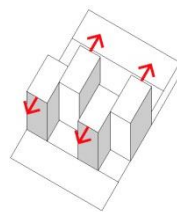
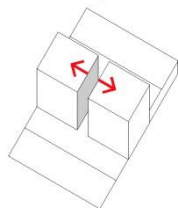
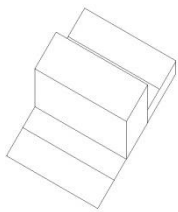
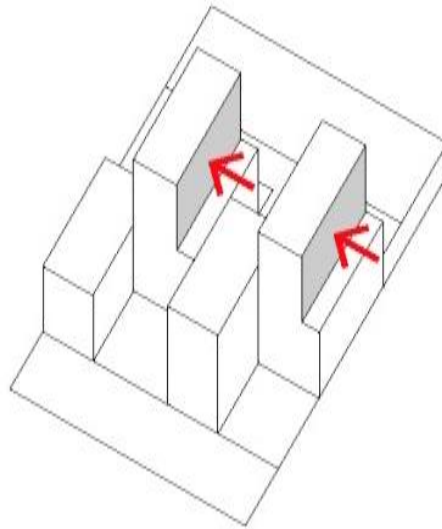

...volumes adjusted to generate access paths

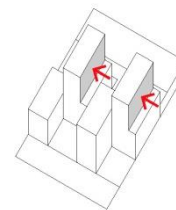
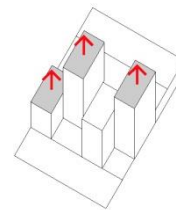
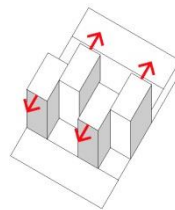
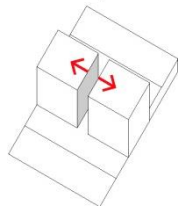
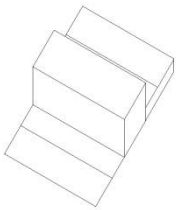
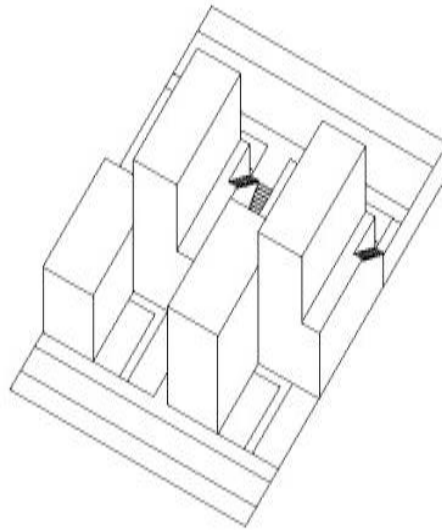

...proposed volumes...

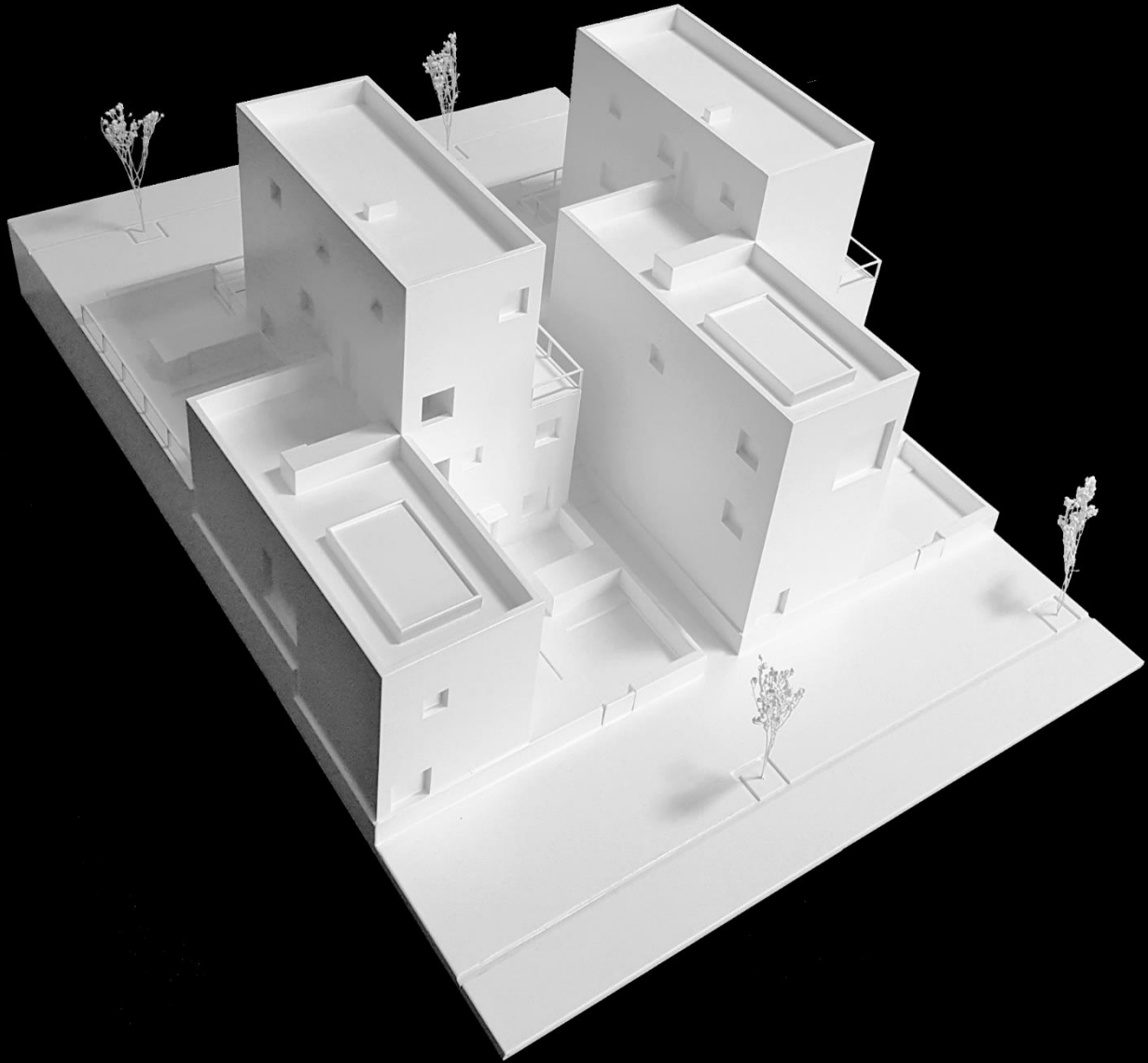

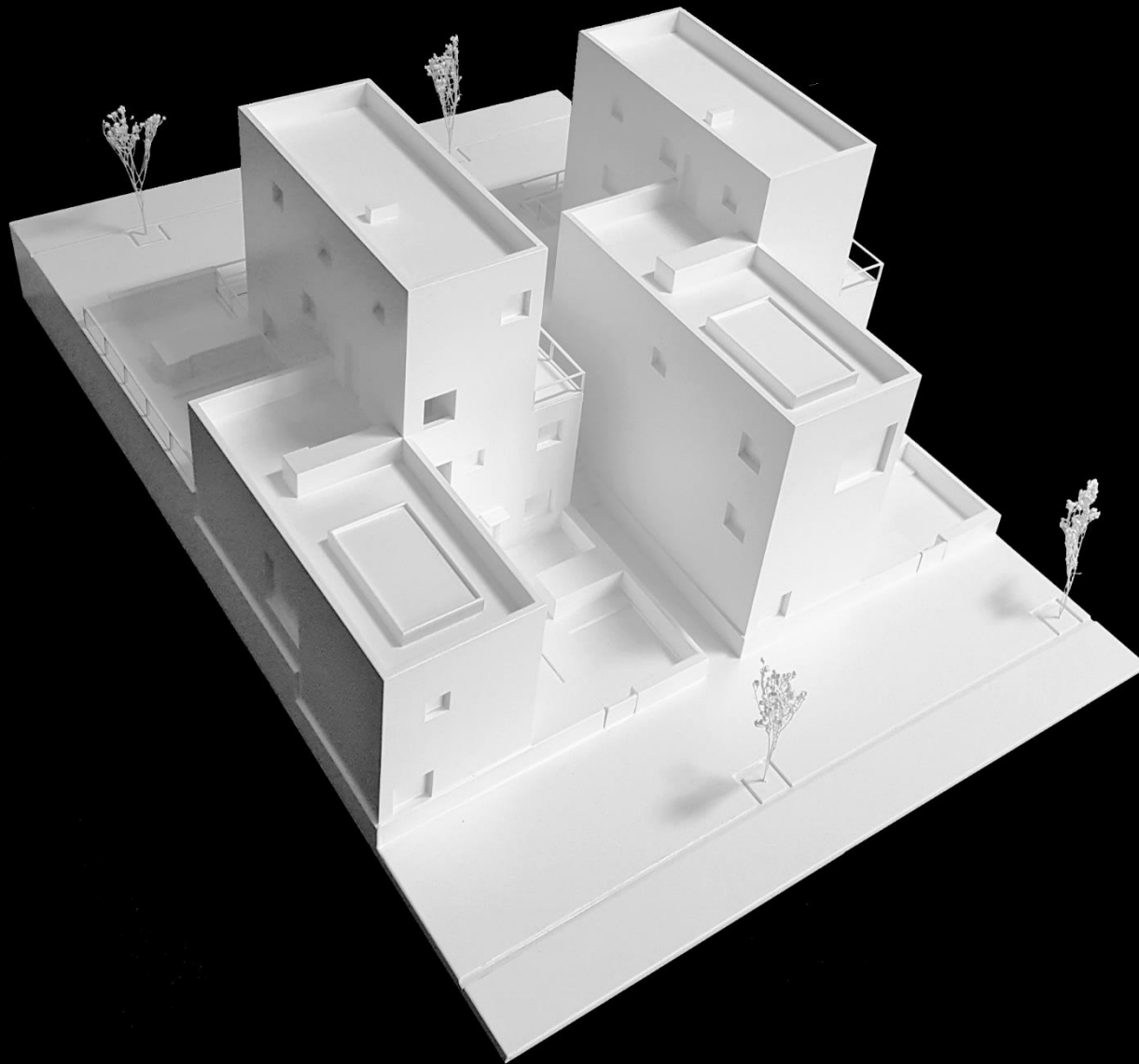

specifications:

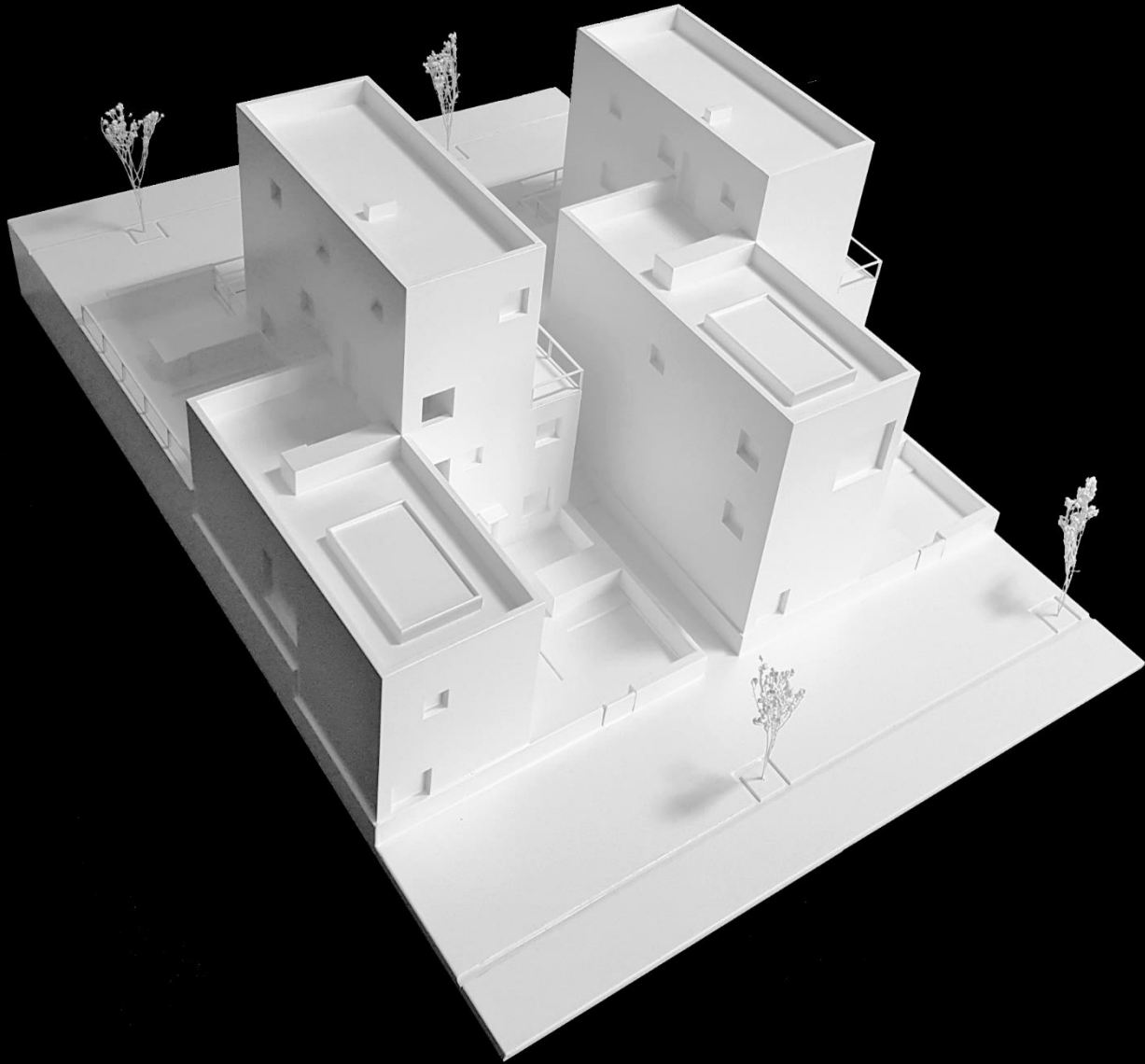

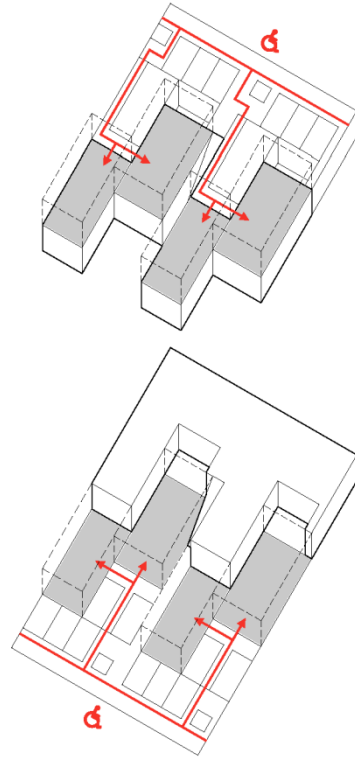

step free access to 80% of the accommodation

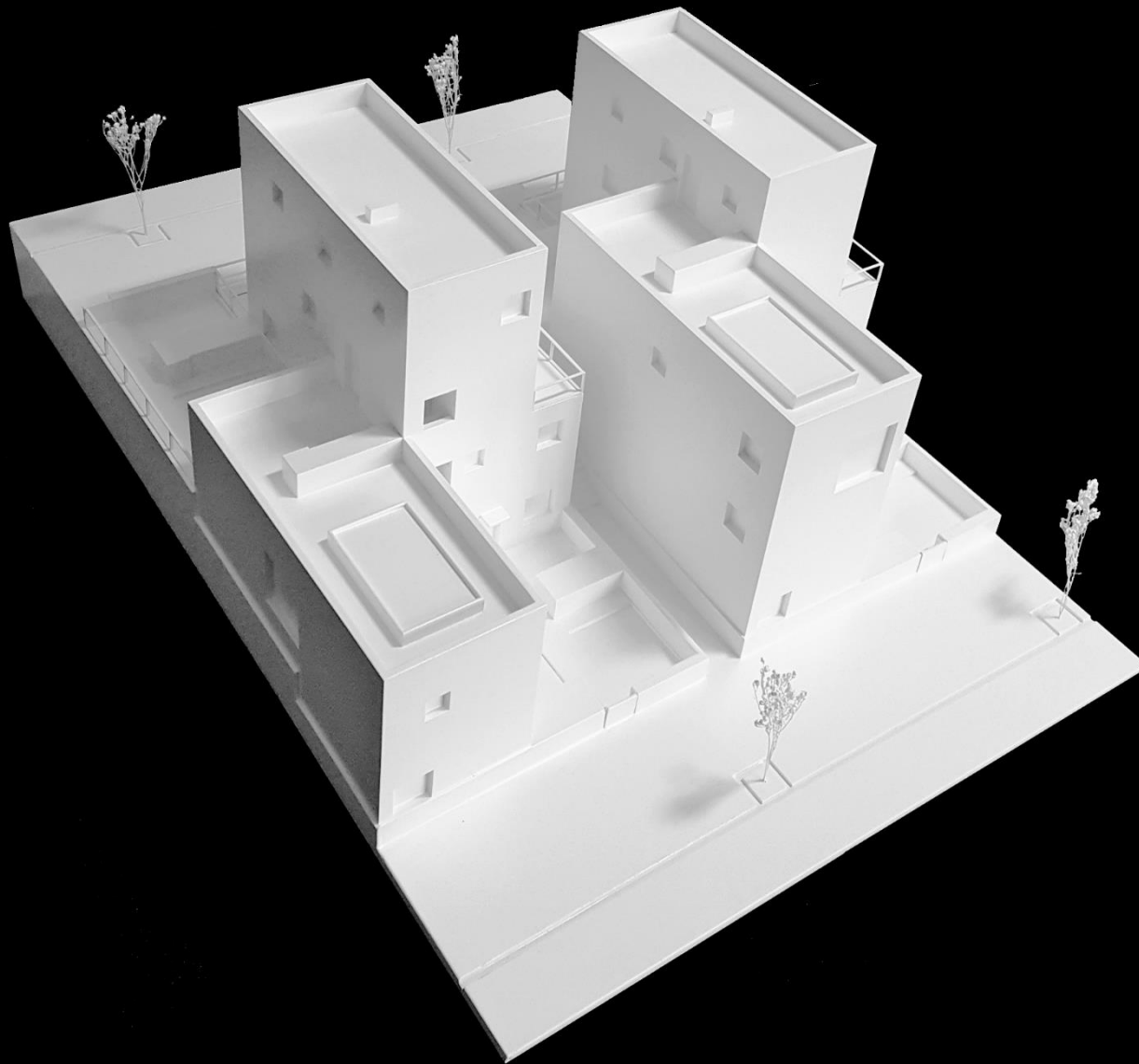

specifications: accessibility + pedestrian paths



Alfama, Lisbon

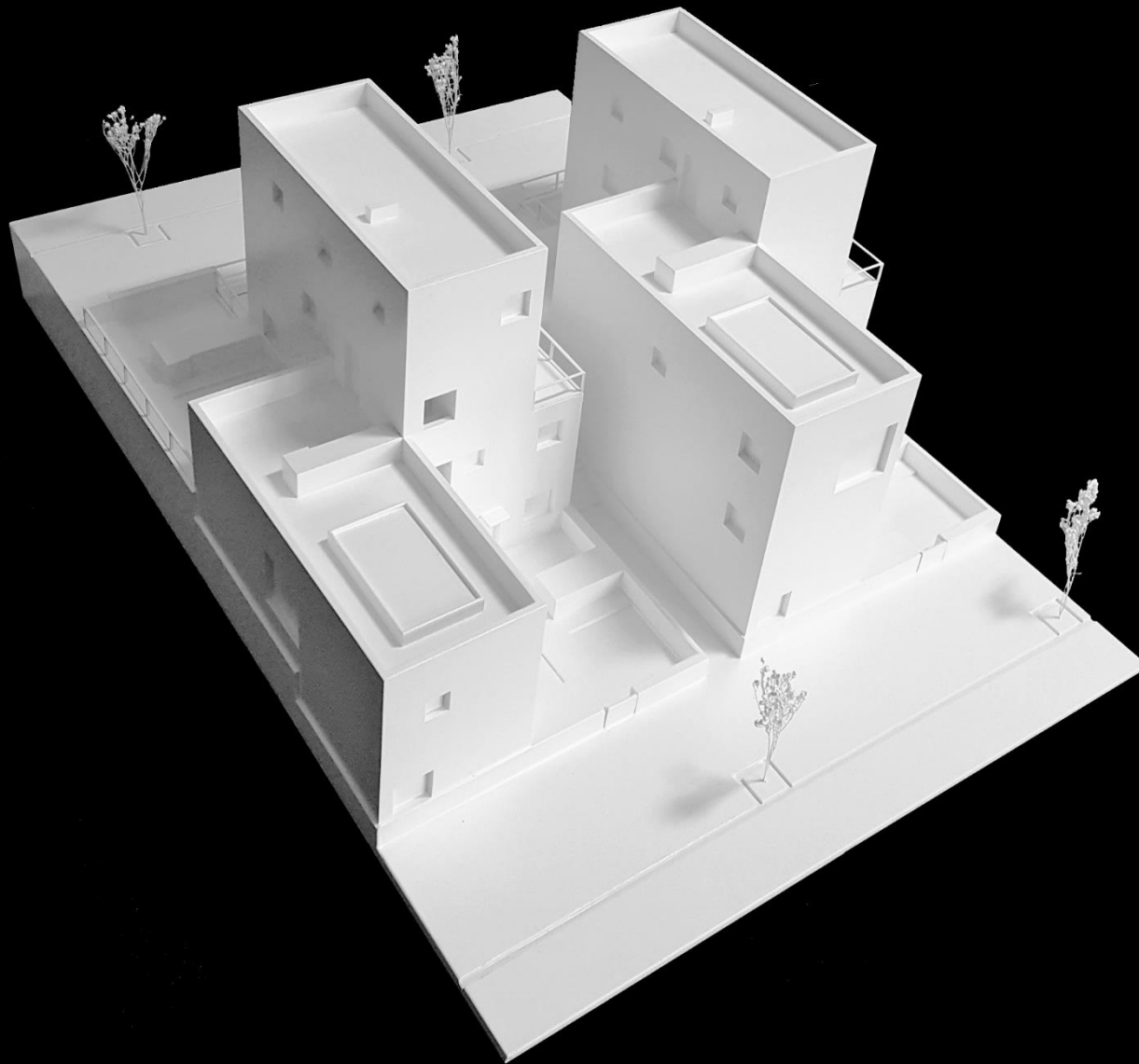

specifications: accessibility + pedestrian paths + urban farming

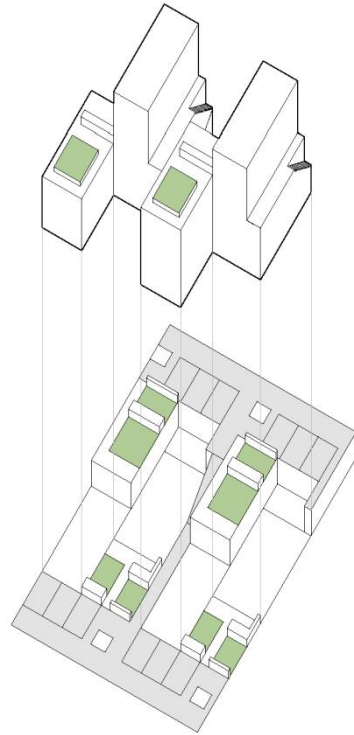

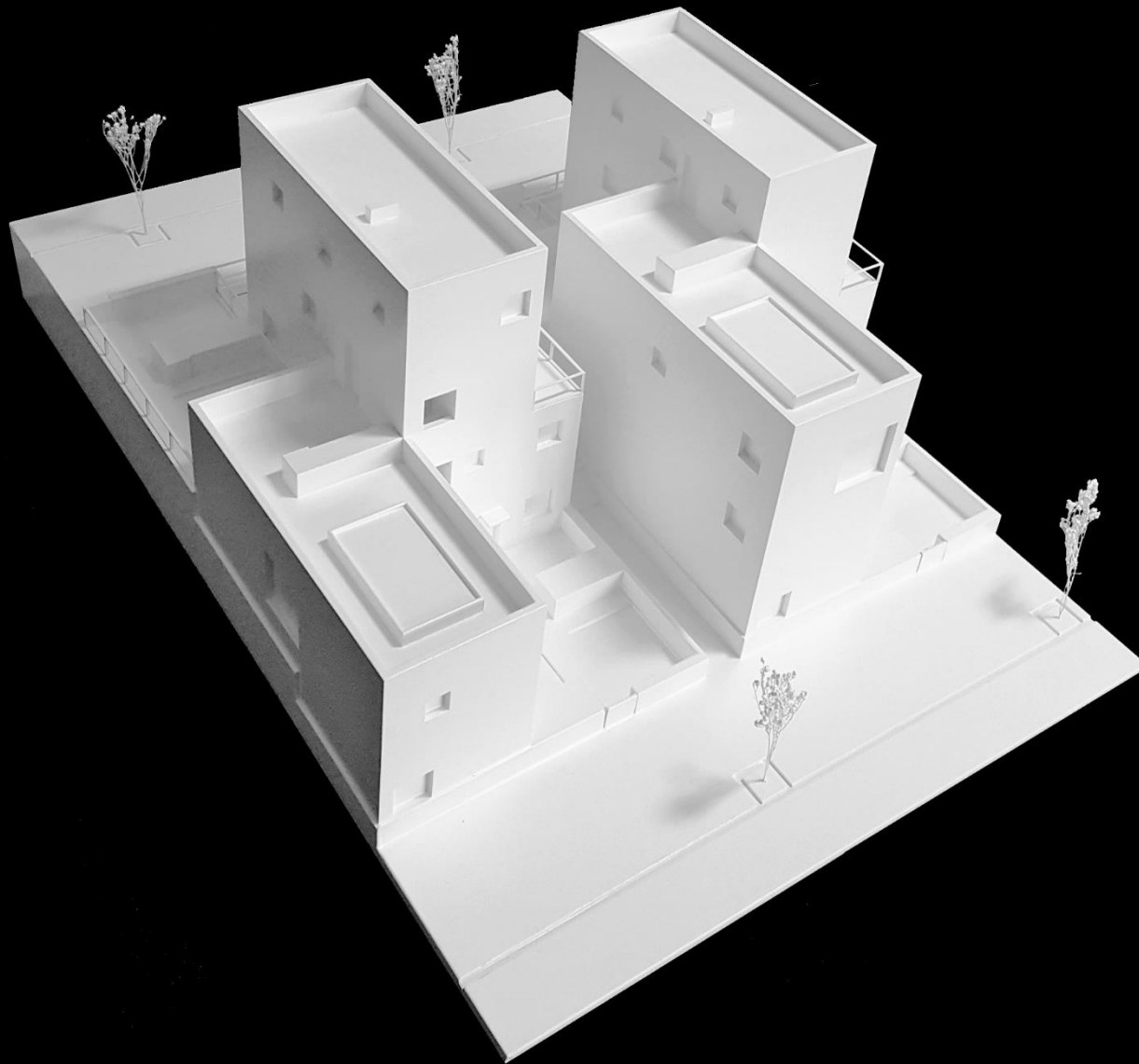

specifications: accessibility + pedestrian paths + urban farming + no common facilities



bairro boavista— lower ground floor



bairro boavista— upper ground floor



bairro boavista— first floor

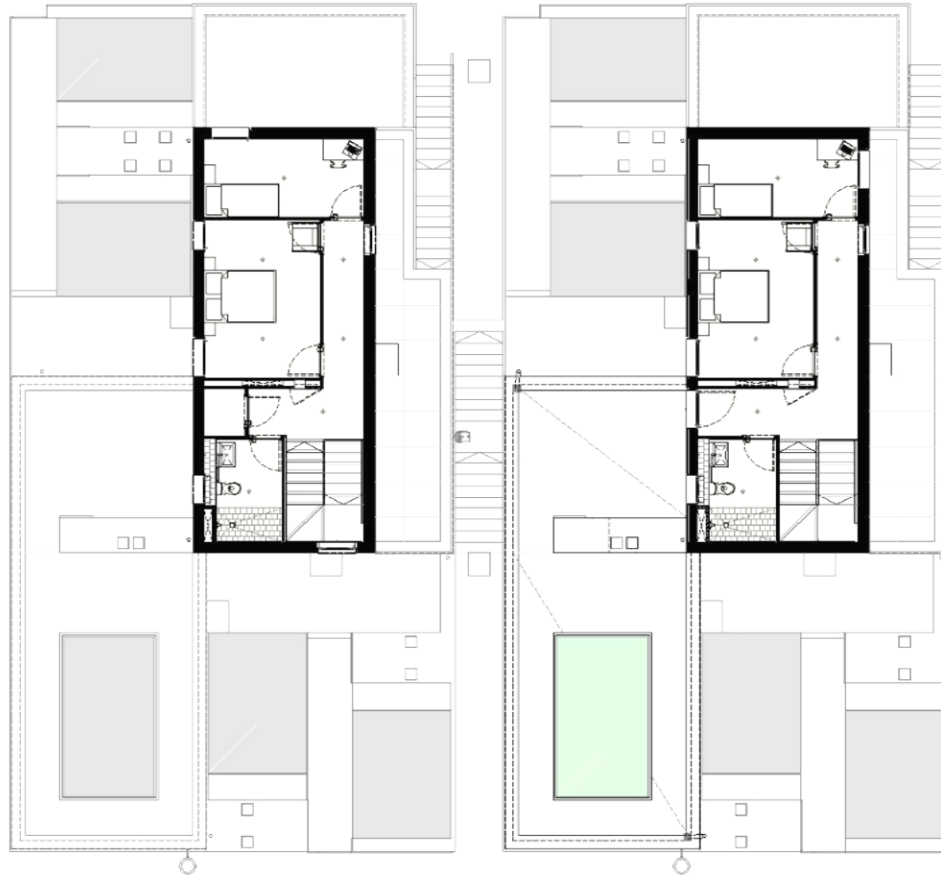

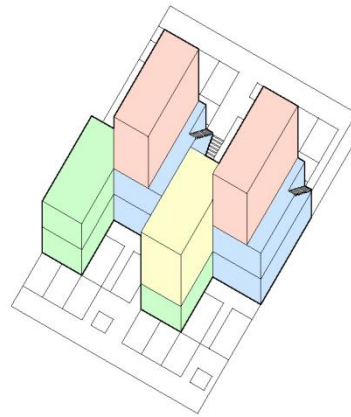

-  1 bedroom
-  2 bedroom
-  4 bedroom
-  3 bedroom



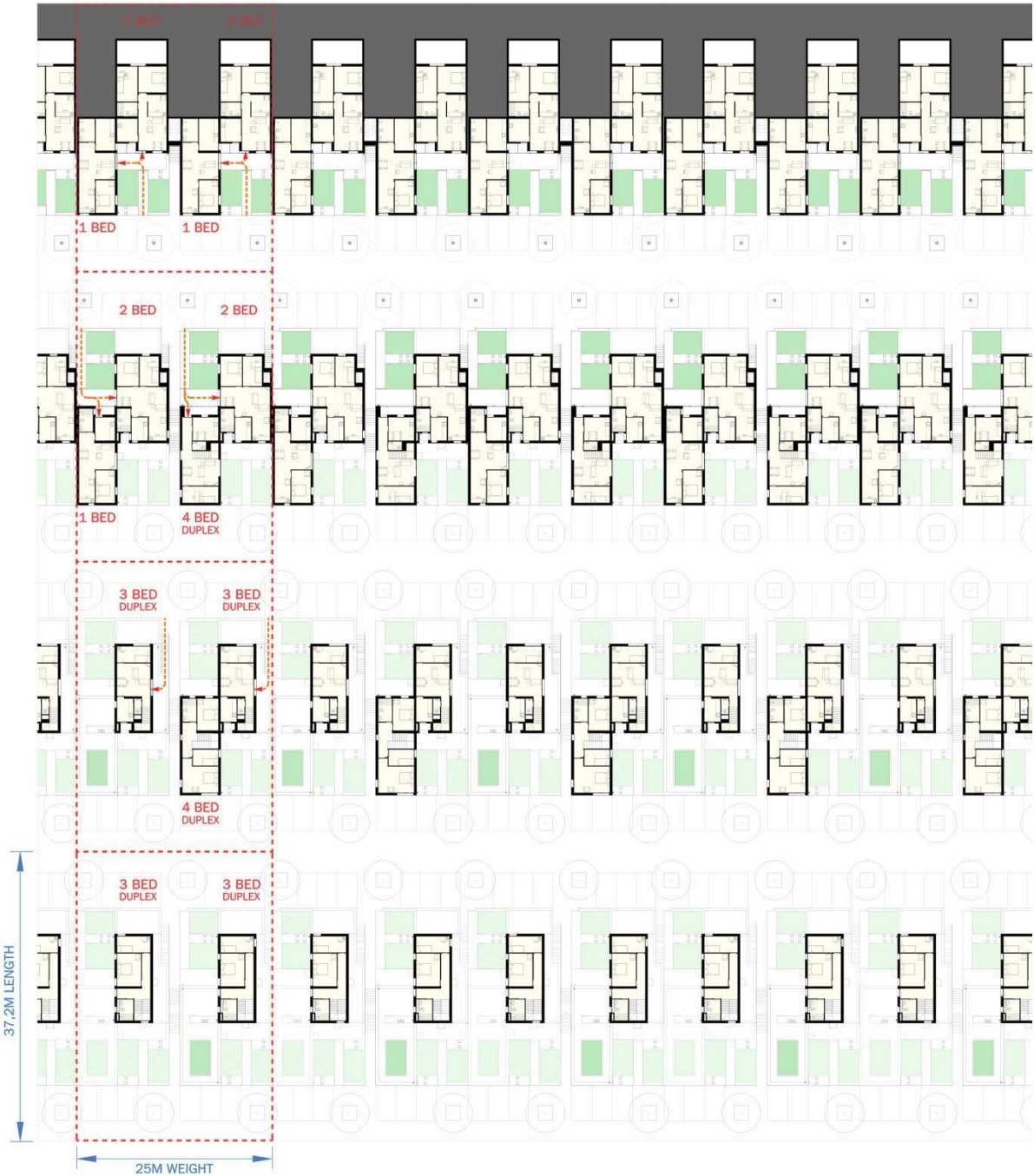

...the urban pattern...

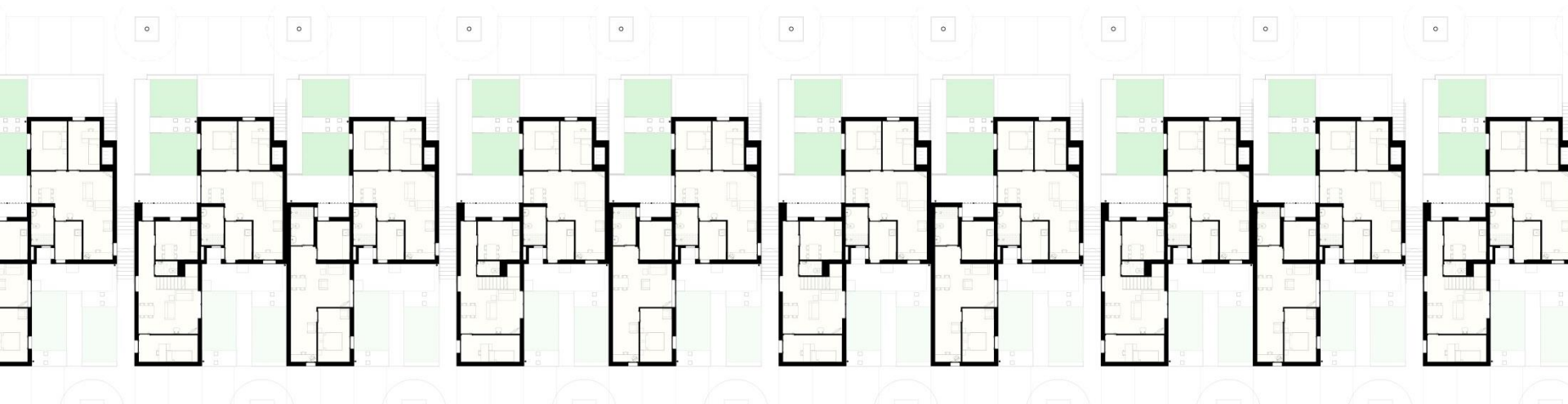

...dilutes boundaries between plots...



the urban pattern dilutes boundaries between plots





house access and pedestrian path



bairro padre cruz – house access and pedestrian path



Bairro da Boavista, 1940's



the model of 10 residential units....



...and its suitability for large scale repetition.

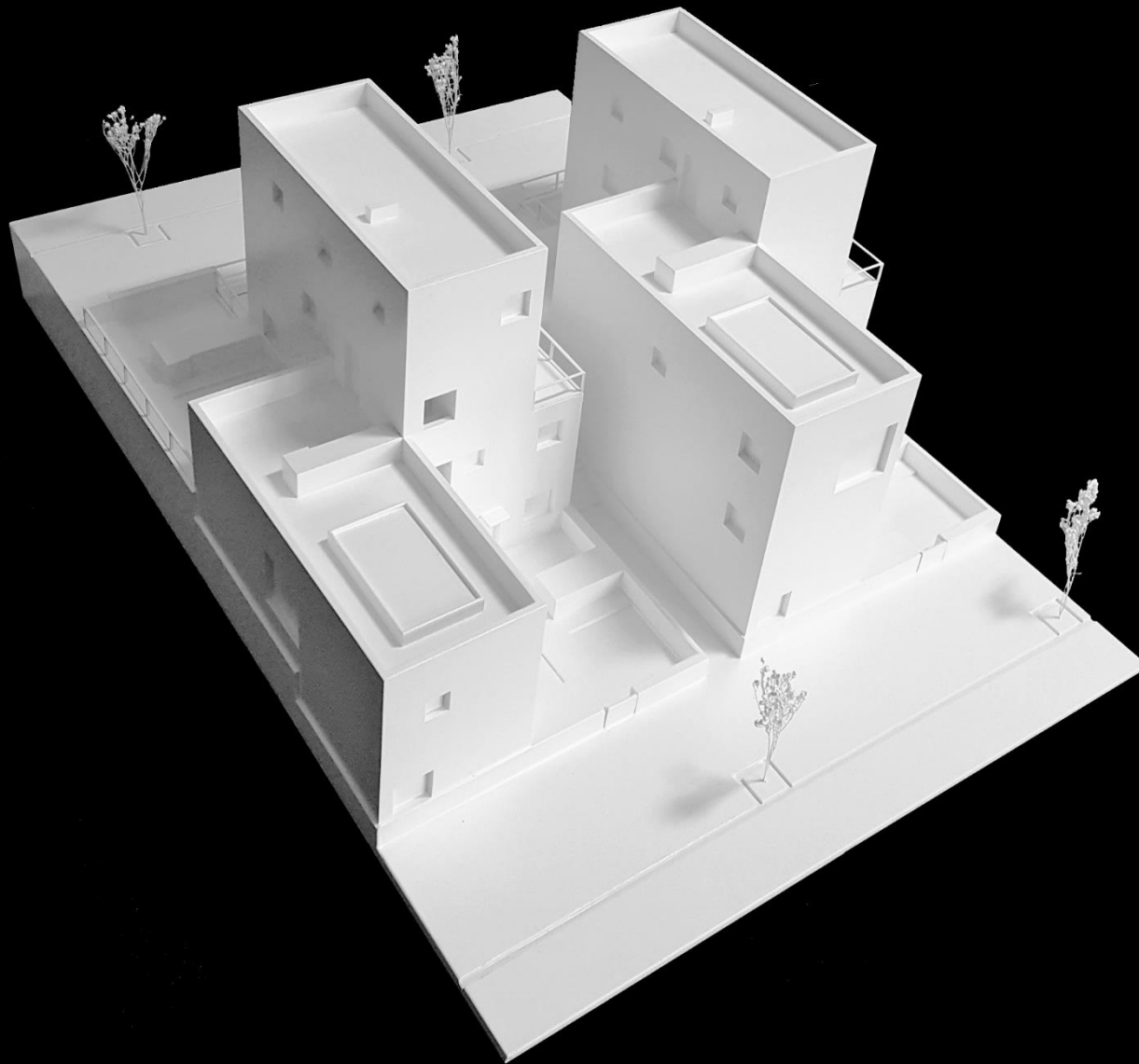

specifications: accessibility + pedestrian paths + urban farming + no common facilities

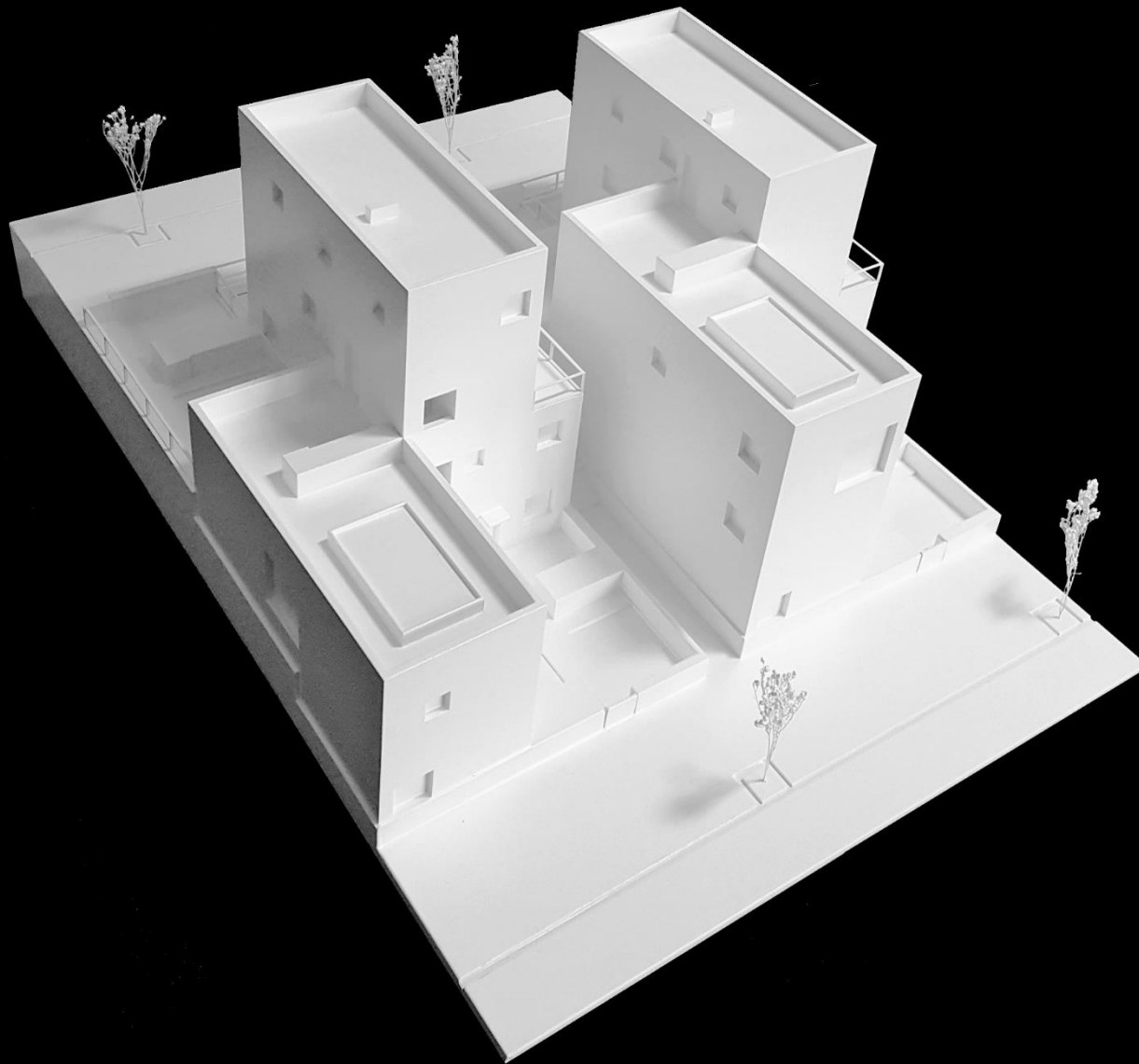

specifications: accessibility + pedestrian paths + urban farming + no common facilities + evolving typologies



from 1 to 2 bedrooms

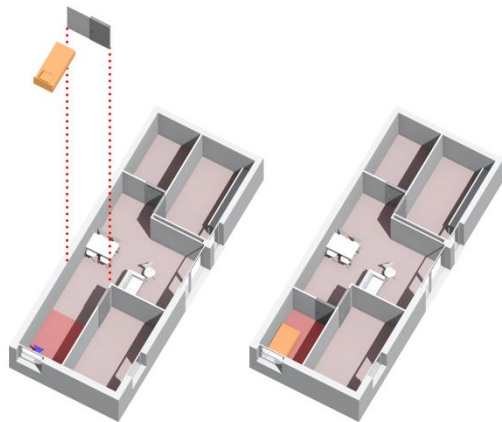

evolving typologies



from 1 to 2 bedrooms



from 2 to 3 bedrooms

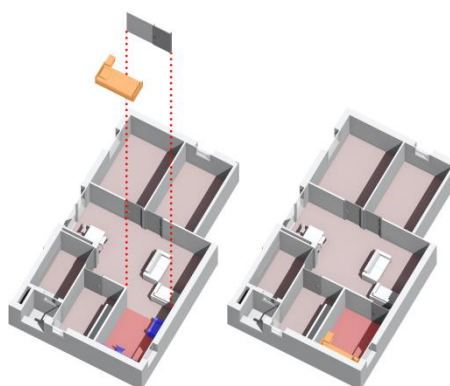
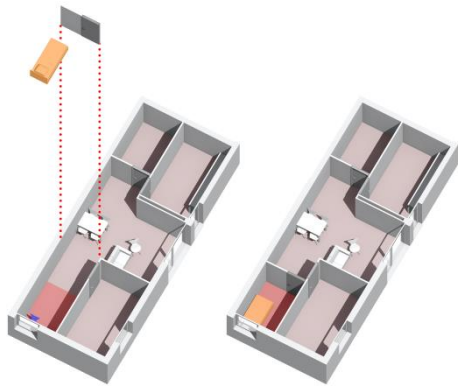



from 1 to 2 bedrooms



from 2 to 3 bedrooms

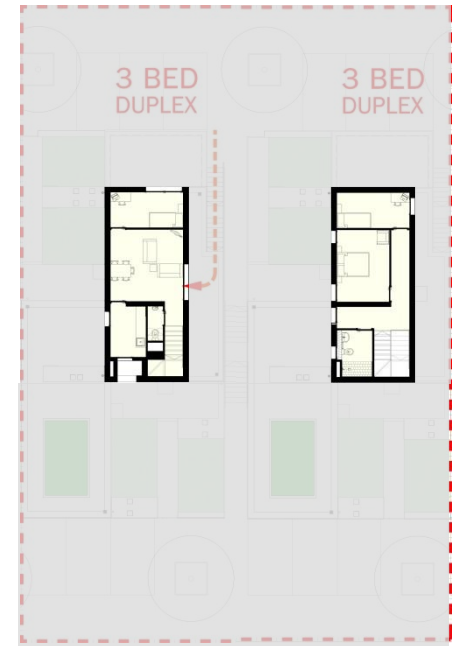

from 3 to 4 bedrooms

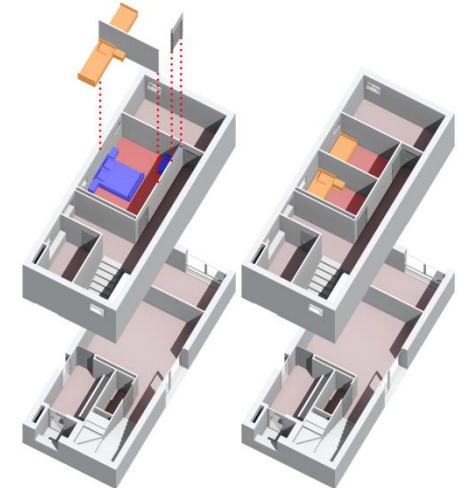
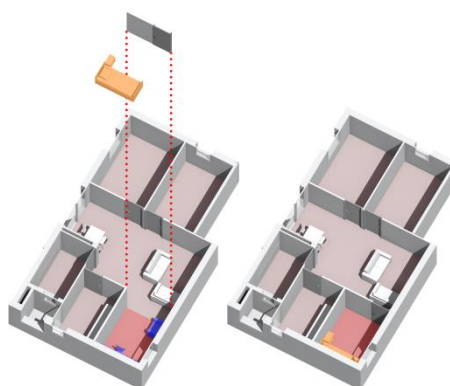
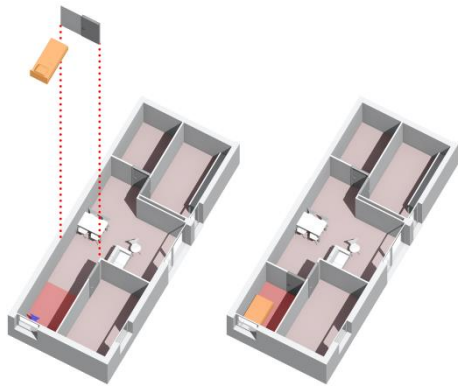

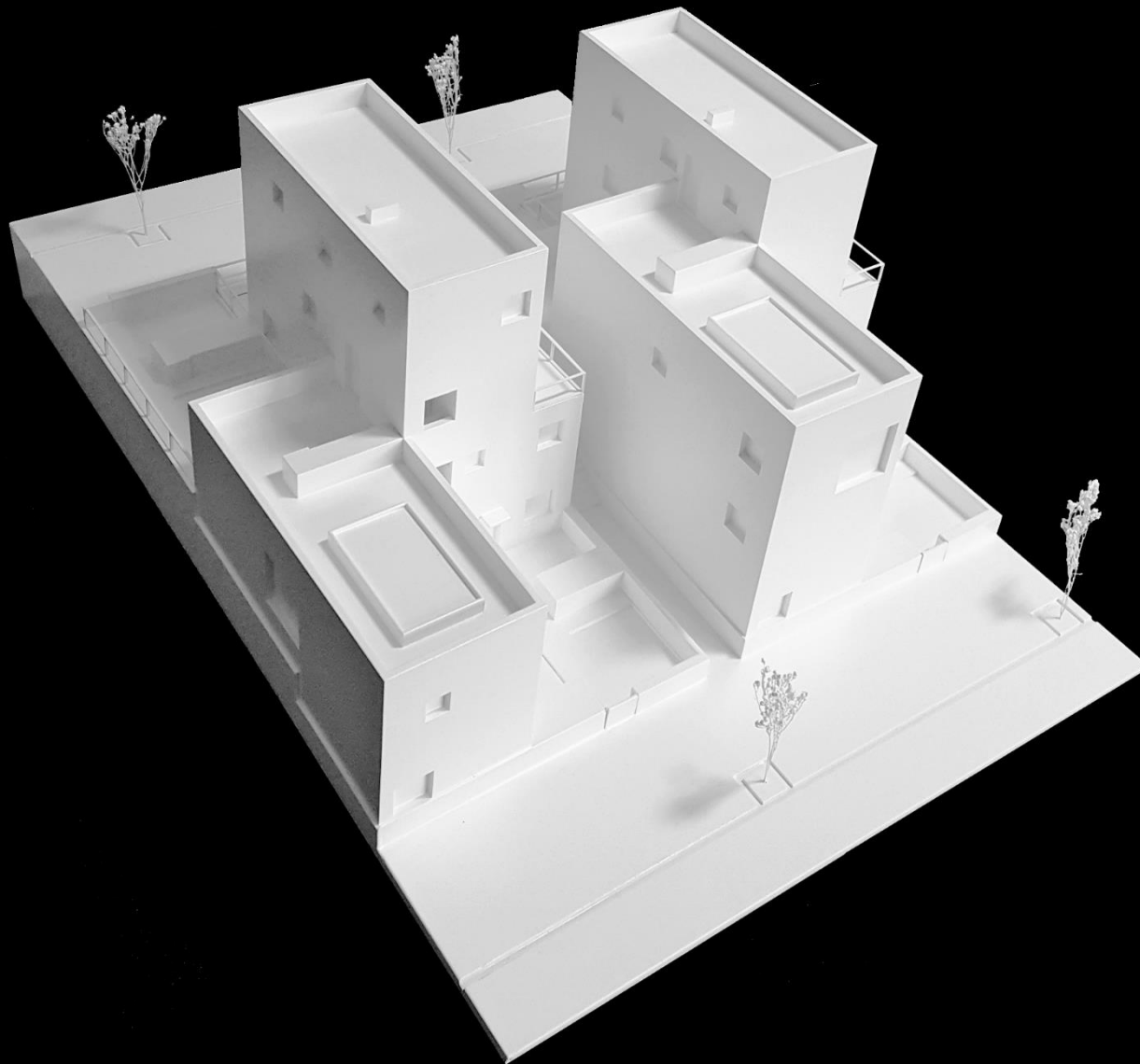

specifications: accessibility + pedestrian paths + urban farming + no common facilities + evolving typologies + rainwater harvesting/ grey water recycling

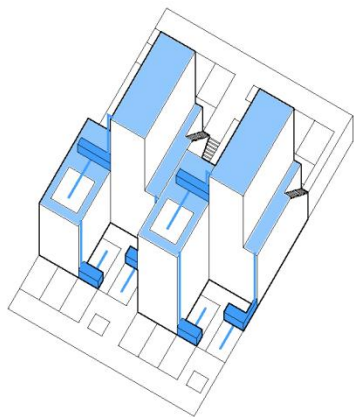



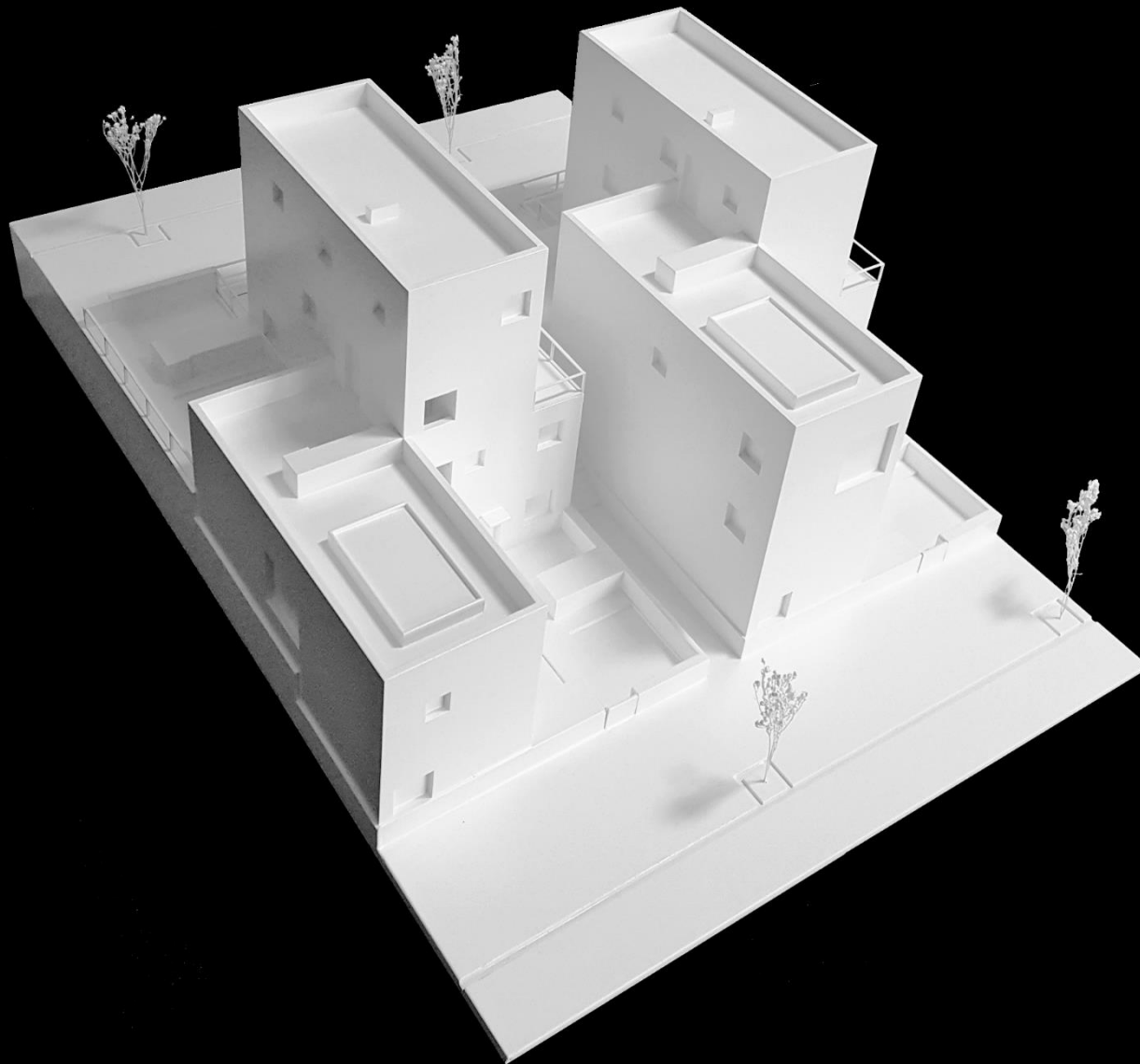

***specifications:** accessibility + pedestrian paths + urban farming + no common facilities + evolving typologies + rainwater harvesting/ grey water recycling + low maintenance costs + passive solar design*

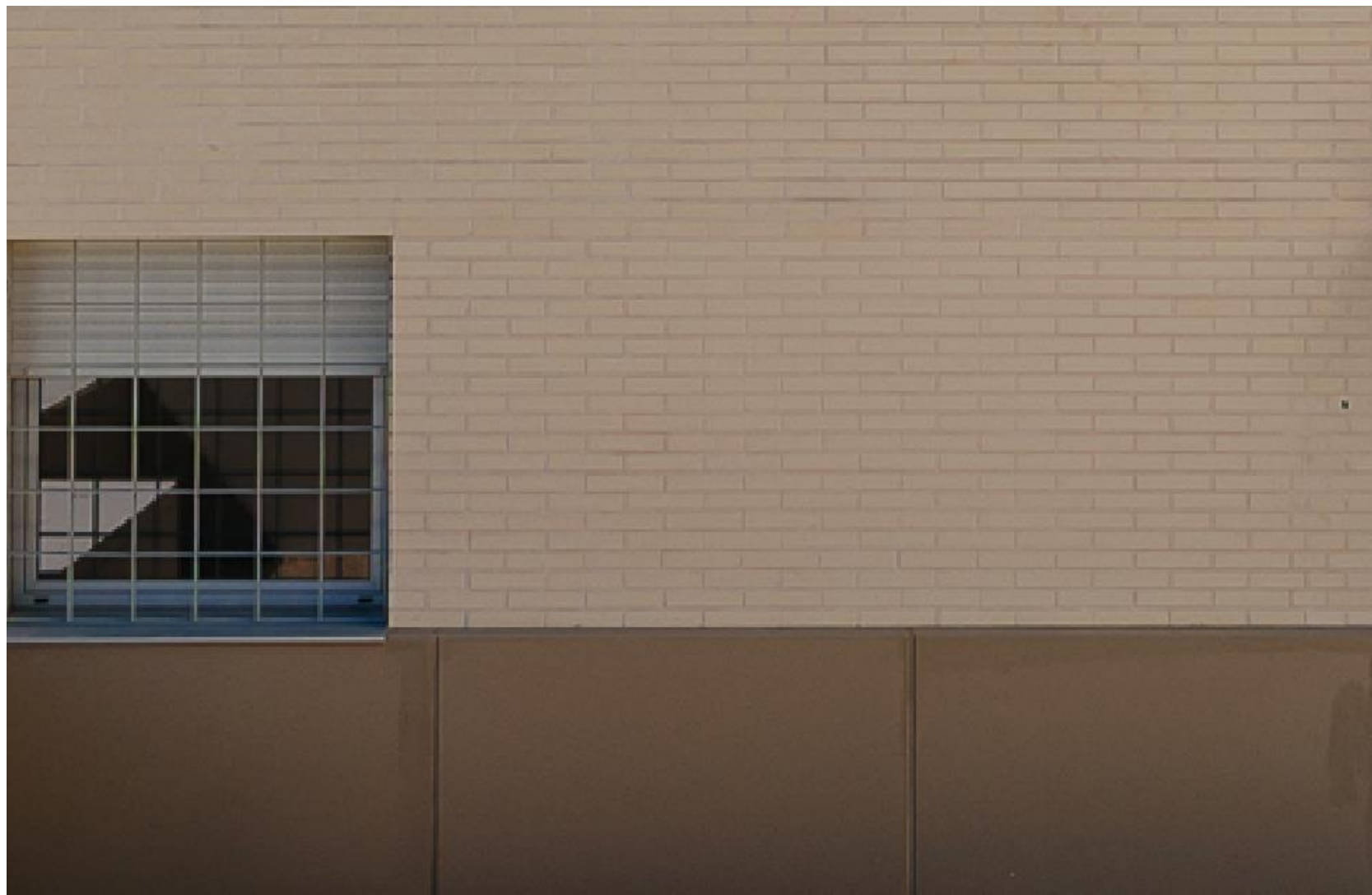

bairro padre cruz —finishing: Klinker Brick and Concrete with exterior insulation system

que seja assim o arquitecto - homem entre os homens - organizador do espaço - criador de felicidade

Fernando Távora



bairro padre cruz – two bed house: access and living room



bairro padre cruz – three bed house: bedroom



bairro padre cruz – one bed house: access and living room



bairro padre cruz – one bed house: access and kitchen



bairro padre cruz – three bed house: access and living room



bairro padre cruz – three bed house: kitchen access and living room



bairro padre cruz – three bed house: kitchen access and living room



bairro padre cruz – three bed house: kitchen access and living room



bairro padre cruz – three bed house: staircase and bathroom access



bairro padre cruz – three bed house: staircase



bairro padre cruz – three bed house: kitchen



bairro padre cruz – three bed house: bathroom



bairro padre cruz – three bed house: terrace access



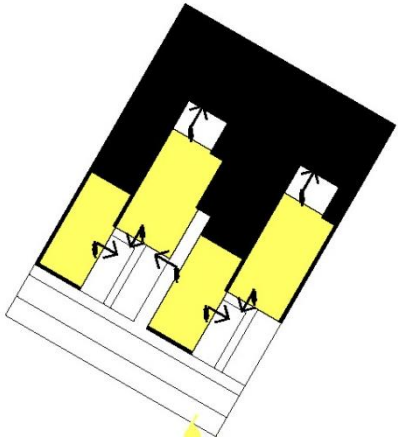

lower ground floor

multiple orientation

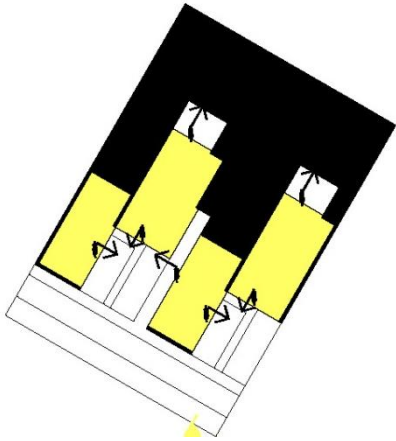

lower ground floor

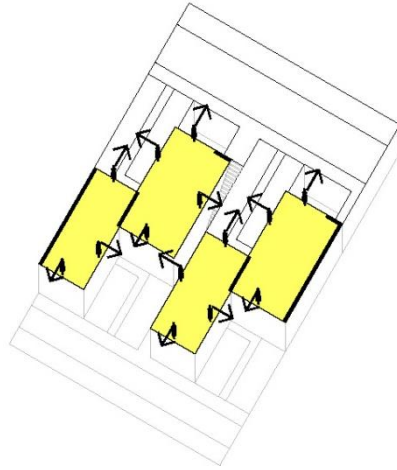

upper ground floor

multiple orientation

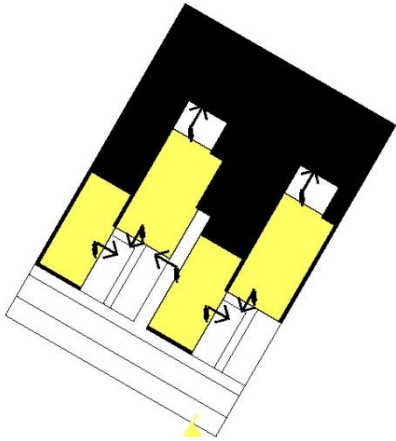

lower ground floor

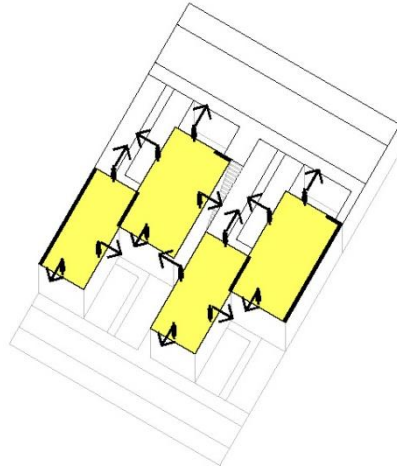

upper ground floor

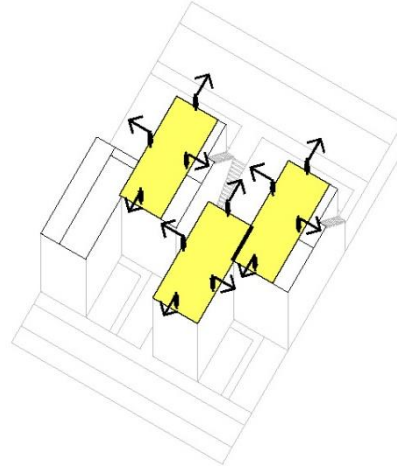

first floor

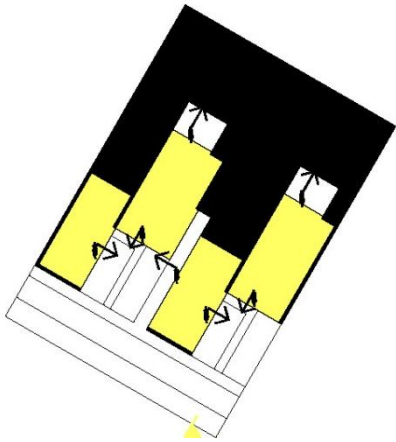

lower ground floor

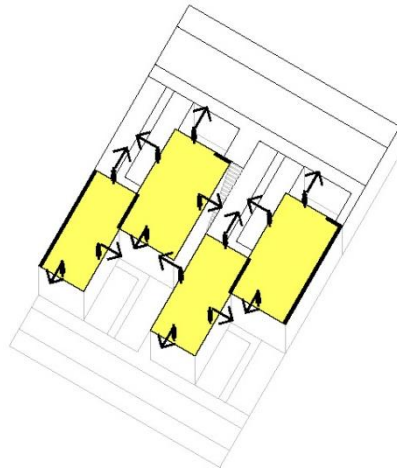

upper ground floor

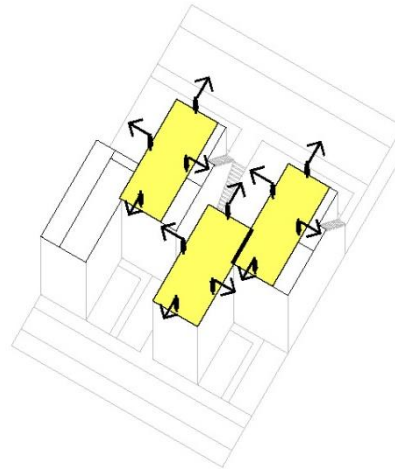

first floor

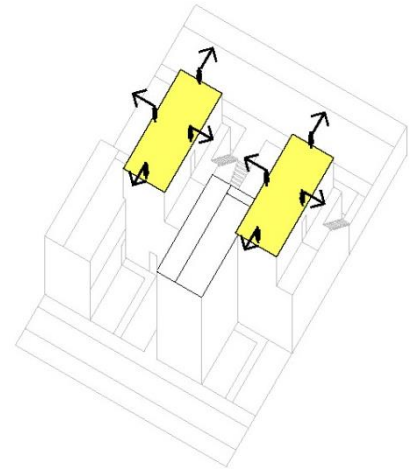

second floor

multiple orientation

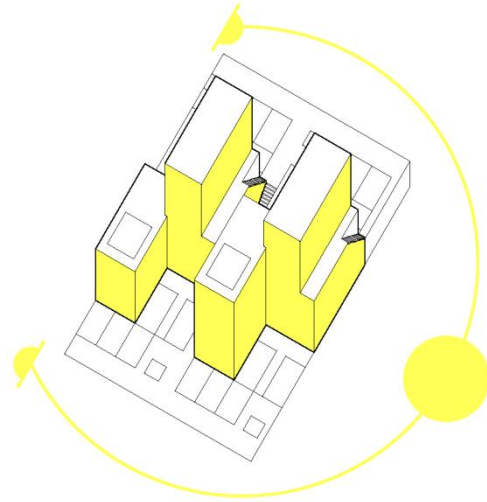

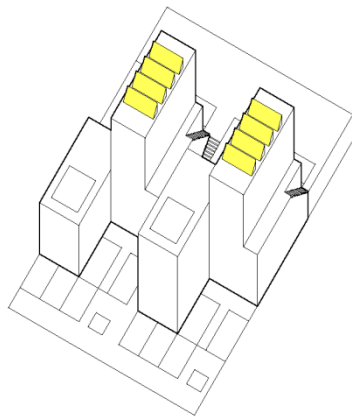



20 homes

“reabilitação urbana da zona de alvenarias do bairro padre cruz, quarteirão piloto (lote 02)”



50 homes



130 homes

“adaptação do edifício-tipo da boavista/padre cruz no terreno da malha 23.2 do pual”



200 homes

the miracle of multiplication



the site, bairro padre cruz



the site, bairro da boavista



the site, bairro dos sete céus / alta de lisboa (future neighborhood for bairro da cruz vermelha's residents)

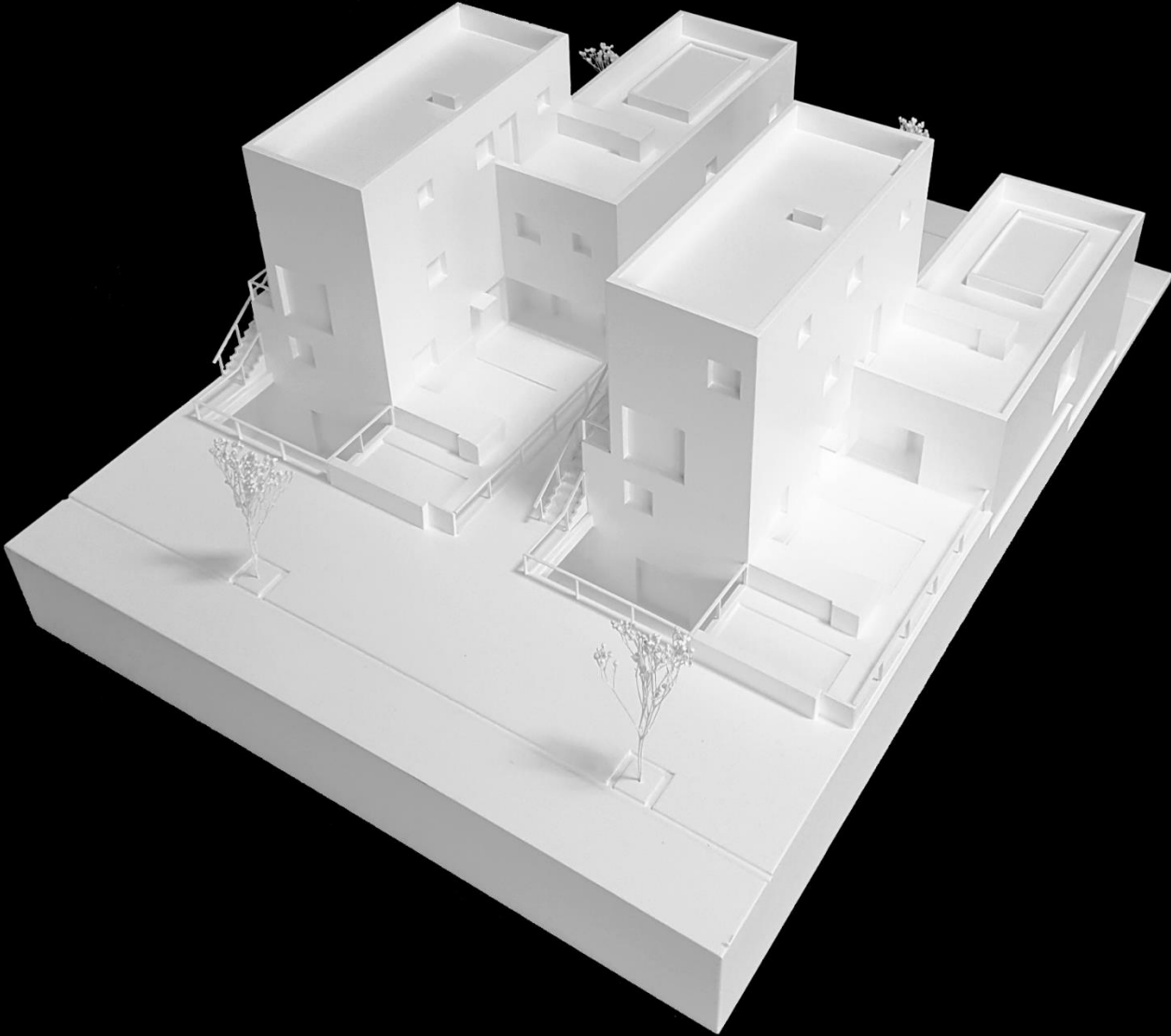

















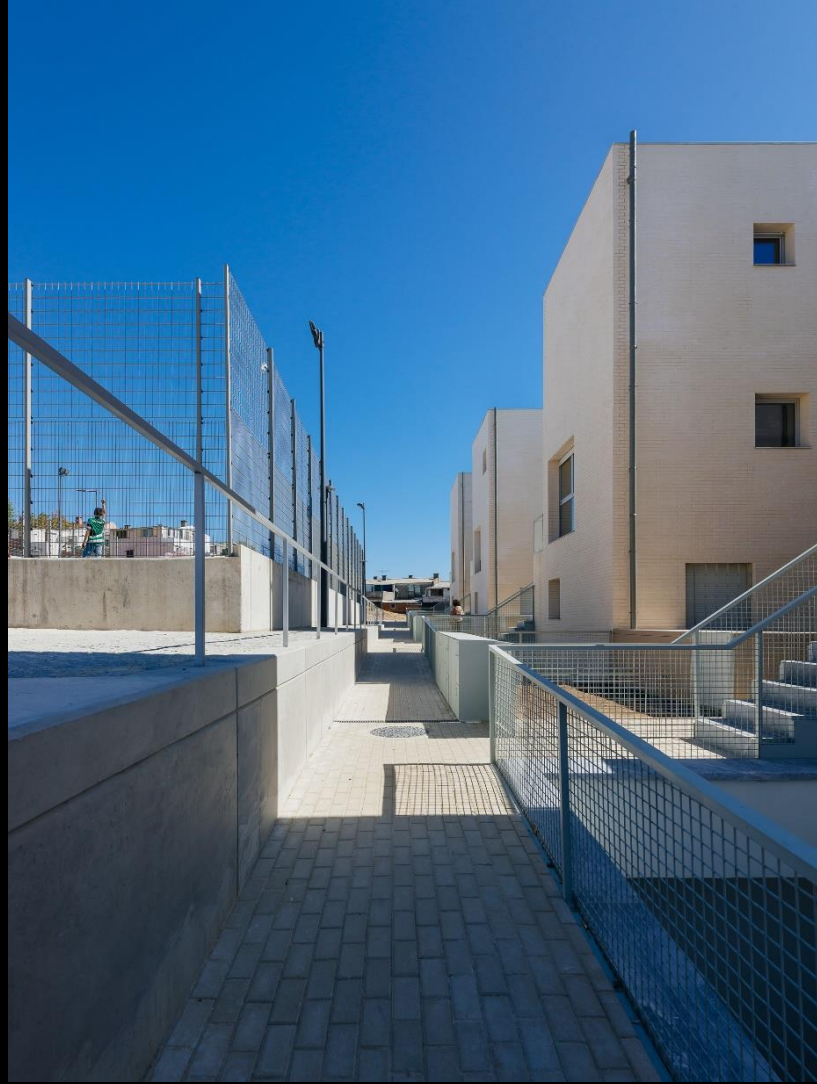

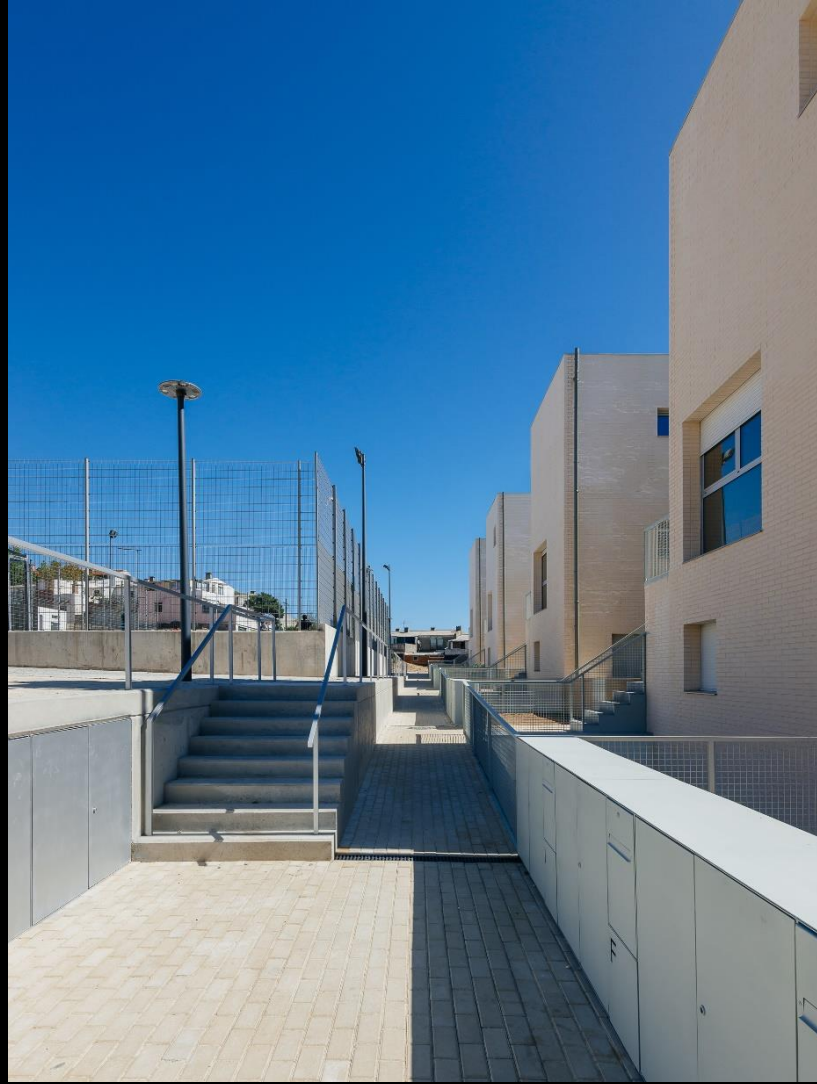

















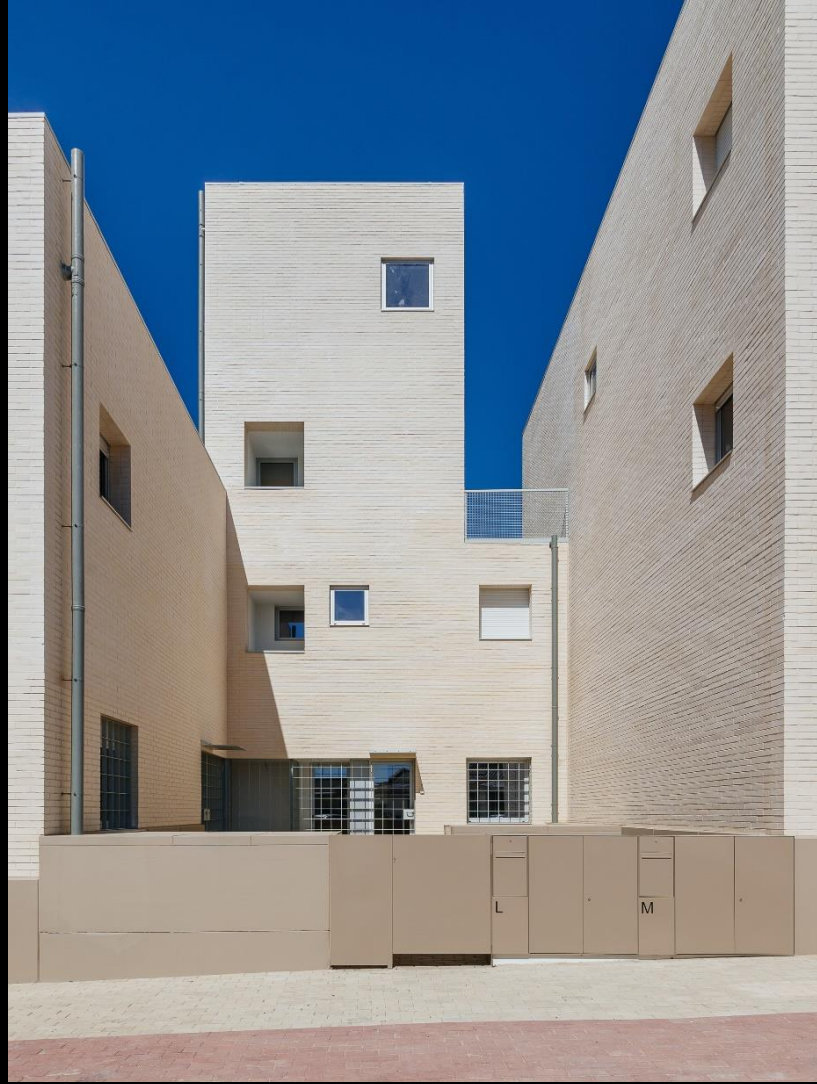





















e uma casa é a coisa mais séria da vida Ruy Belo

Alvenaria Social Housing Project (2013-....)

Lisbon, Portugal

Padre Cruz: Twenty Homes

Boavista Phase 1: Fifty Homes plus Infrastructure Works

Sete Céus: One Hundred and Thirty Homes plus Infrastructure Works

a project by

Alexandre Dias, Bruno Silvestre & Luis Spranger

Collaborators

Tiago Nunes da Costa, Daniela Santos, Luis Salazar, Miguel Serpa Oliva, Daniel Gameiro,
Ana do Vale Lopes, Elísio Graça, Nuno Pereira, Paulo Teixeira, João Portugal, Rui Santos,
Nuno Sequeiros, José António Andrade, John Marshall, Joana Gouveia

Photographs

do mal o menos

Music

Bbv: guetto dy bairro da boavista





muito obrigado!